

PanZone™ 水平系スラック用ケーブルポスト

Part Numbers: PZBR3, PZBR4

©Panduit Corporation Japan Branch

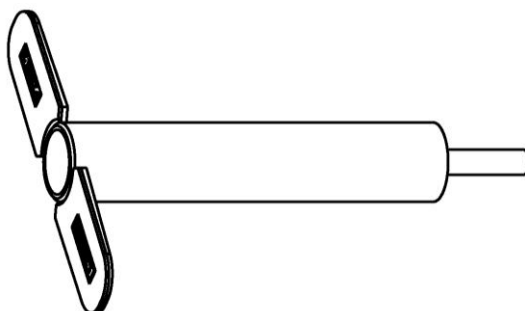

製品仕様

材質	プラスチック
----	--------

環境性能

使用環境	使用温度範囲	-10 ~ +60 [°C]
	使用湿度範囲	25 ~ 85 [%] (結露なきこと)
	設置場所	事務所・住宅等の屋内のみ (水気・直射日光・機械的衝撃・過重等は厳禁)

寸法 詳細は別紙寸法図を参照(寸法はインチとなり、[]内はメートル表示です)

公称寸法 (公差±0.13 [mm])	PZBR3	W 69.81 × Φ 15.24 × H 78.10 [mm]
	PZBR4	W 69.81 × Φ 15.24 × H 103.50 [mm]

質量

公称重量	PZBR3	90 [g]
	PZBR4	110 [g]

カラー

カラー	BL (黒)
-----	--------

取付ネジ

ネジ	PZBR3	#12-24 × 38.1	2本
	PZBR4	#12-24 × 63.5	2本

含有化学物質調査

調査項目	RoHS 対応済み	現用品
------	-----------	-----

版	制定	作成	承認
01	2012年12月20日	猿渡	今野

改版履歴

版数	改版日	変更内容	担当
01	2012.12.20	初版制定	猿渡

版	制定	作成	承認
01	2012年12月20日	猿渡	今野

THIS COPY IS PROVIDED ON A RESTRICTED BASIS AND IS NOT TO BE USED IN ANY WAY DETRIMENTAL TO THE INTERESTS OF PANDUIT CORP.

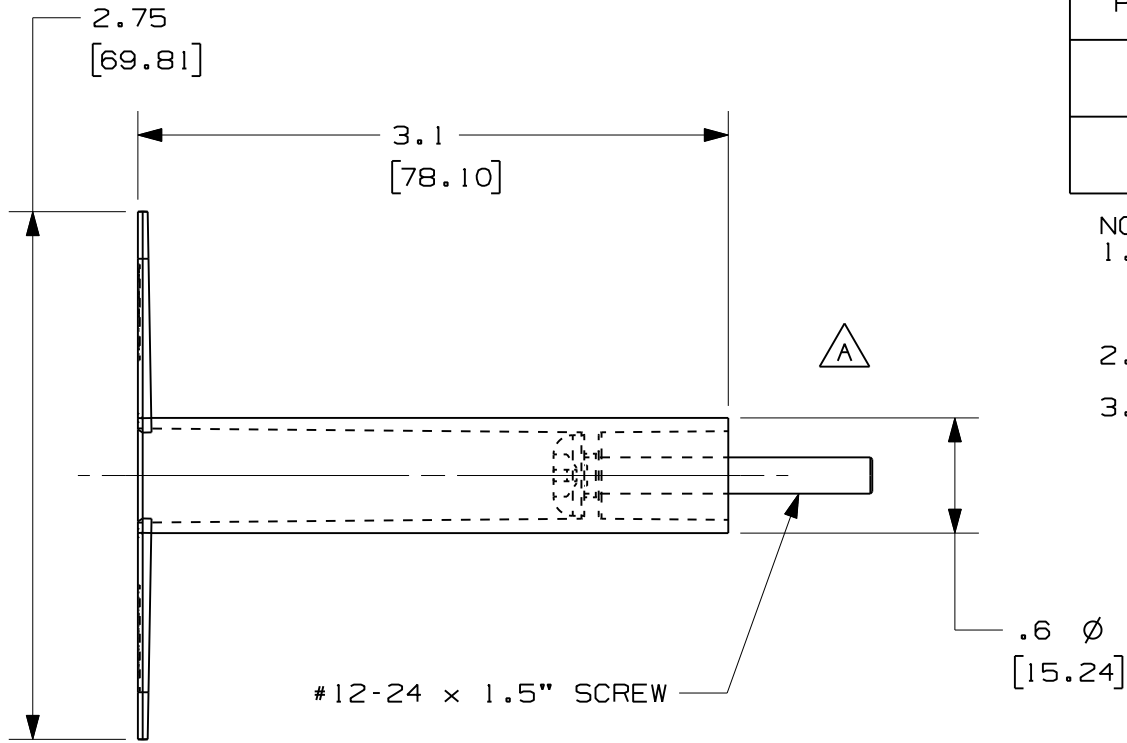

PANDUIT PART NO.	WEIGHT
PZBR3	0.2 LBS/EACH 0.09 Kg/EACH
PZBR3-X	(10) PZBR3's

NOTES:

- VISIT OUR ON-LINE CATALOG AT WWW.PANDUIT.COM FOR A CURRENT LIST OF PRODUCTS APPLICABLE FOR USE WITH THIS PART.
- COMPONENTS: (2) BEND RADIUS POSTS
(2) #12-24 x 1.5" SCREWS
- DIMENSIONS IN PARENTHESIS ARE METRIC.

MODEL FILENAME V10290EG_SMGMTPOST_02.PRT

CAD FILENAME/LAYERS V10290EG_DC_00B.PRT

PANDUIT CORP. TINLEY PARK, ILLINOIS

3" BEND RADIUS POST (PZBR3)
CUSTOMER DRAWING

UNLESS OTHERWISE SPECIFIED, DIMENSIONAL TOLERANCES ARE:
 INCHES X.X +/- 0.03 X.XX +/- 0.015 X.XXX +/- 0.005
 [METRIC - MILLIMETER] X.X +/- 0.8 X.XX +/- 0.4 X.XX +/- 0.13
 ANGLE +/- 1°

UNLESS OTHERWISE SPECIFIED,
ALL DIMENSIONS ARE GIVEN
IN INCHES, THIRD ANGLE PROJECTION.

REV	DATE	BY	CHK	DESCRIPTION	ECN	R	CUST	SUP	OTH
01	7-30-07	MAV		A. ADDED DIMENSIONED VIEW.	10290-67				
00	12-14-06	MAV	BAS	RELEASED TO PRODUCTION	10290-67				

DRAWN BY
MAV
DATE
12-14-06
CHK'D
BAS

MAT'L:
N/A

SCALE NONE
DRAWING NO. 10290-67
DWG SIZE A

THIS COPY IS PROVIDED ON A RESTRICTED BASIS AND IS NOT TO BE USED IN ANY WAY DETRIMENTAL TO THE INTERESTS OF PANDUIT CORP.

PANDUIT PART NO.	WEIGHT
PZBR4	0.25 LBS/EACH 0.11 Kg/EACH
PZBR4-X	(10) PZBR4's

NOTES:

- VISIT OUR ON-LINE CATALOG AT WWW.PANDUIT.COM FOR A CURRENT LIST OF PRODUCTS APPLICABLE FOR USE WITH THIS PART.
- COMPONENTS: (2) BEND RADIUS POSTS
(2) #12-24 x 2.5" SCREWS
- DIMENSIONS IN PARENTHESIS ARE METRIC.

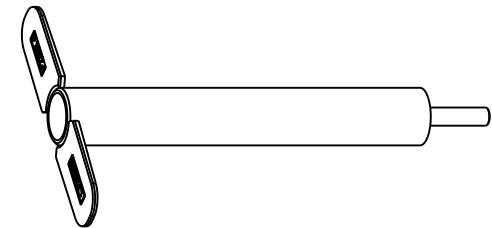
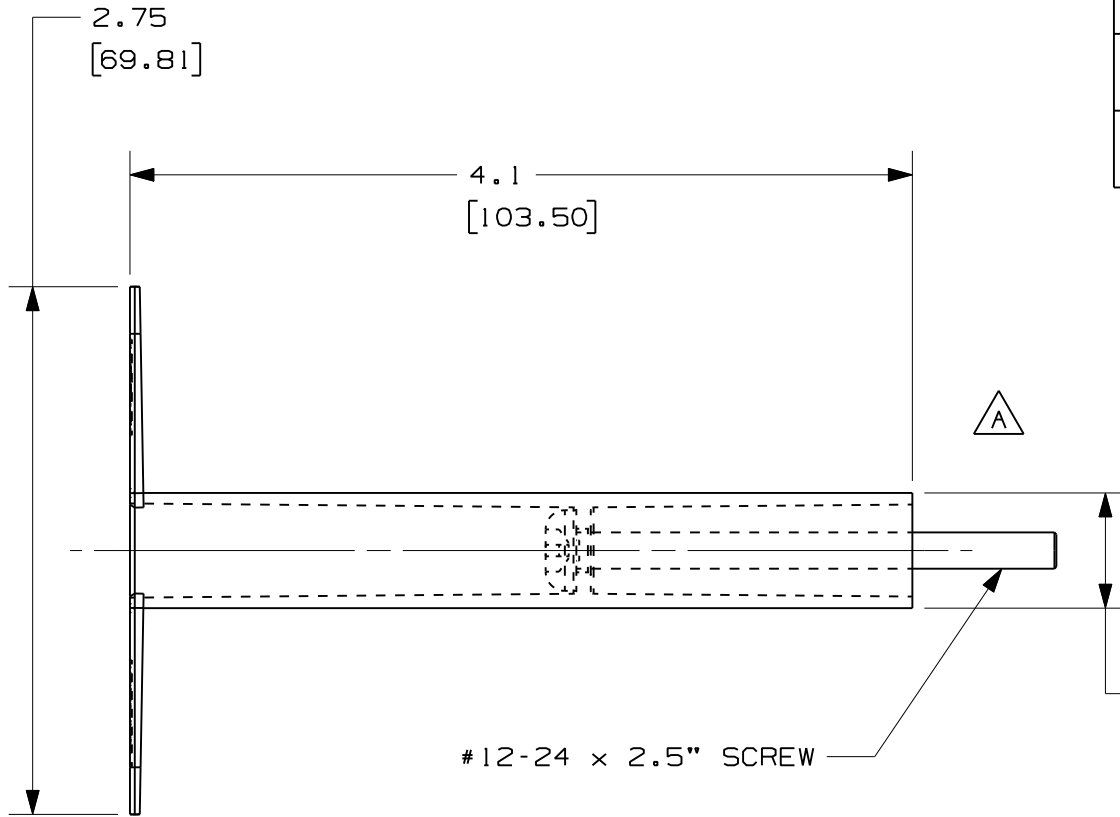

MODEL FILENAME V10290EF_MGMTPOST_07.PRT

CAD FILENAME/LAYERS V10290EF_DC_00B.PRT

PANDUIT CORP. TINLEY PARK, ILLINOIS

4" BEND RADIUS POST (PZBR4)
CUSTOMER DRAWING

UNLESS OTHERWISE SPECIFIED, DIMENSIONAL TOLERANCES ARE:
 INCHES X.X +/- 0.03 X.XX +/- 0.015 X.XXX +/- 0.005
 [METRIC - MILLIMETER] X.X +/- 0.8 X.XX +/- 0.4 X.XX +/- 0.13
 ANGLE +/- 1°

UNLESS OTHERWISE SPECIFIED,
ALL DIMENSIONS ARE GIVEN
IN INCHES, THIRD ANGLE PROJECTION.

REV	DATE	BY	CHK	DESCRIPTION	ECN	R	CUST	SUP	OTH
01	7-30-07	MAV		A. ADDED DIMENSIONED VIEW.	10290-65				
00	12-6-06	MAV	BAS	RELEASED TO PRODUCTION	10290-65				

DRAWN BY
MAV
DATE
12-6-06
CHK'D
BAS

MAT'L:
N/A

SCALE NONE
DRAWING NO. 10290-65
DWG SIZE A